



What Are Buried Ducts, Do They Work, and How Do You Install Them?

RESNET Building Performance Conference

February 28, 2018

Katrina Keeley (katrina.keeley@owenscorning.com)

Mark Smith (mark.h.smith@owenscorning.com)

Codes push for energy efficiency



- Energy codes continue to progress toward reduced energy usage.
- Zero energy homes are the future:
 - California goal is 2020
 - U.S. goal is 2030
- Building practices must evolve to meet demanding codes and energy efficiency.
- High performance systems drive toward improved home performance.

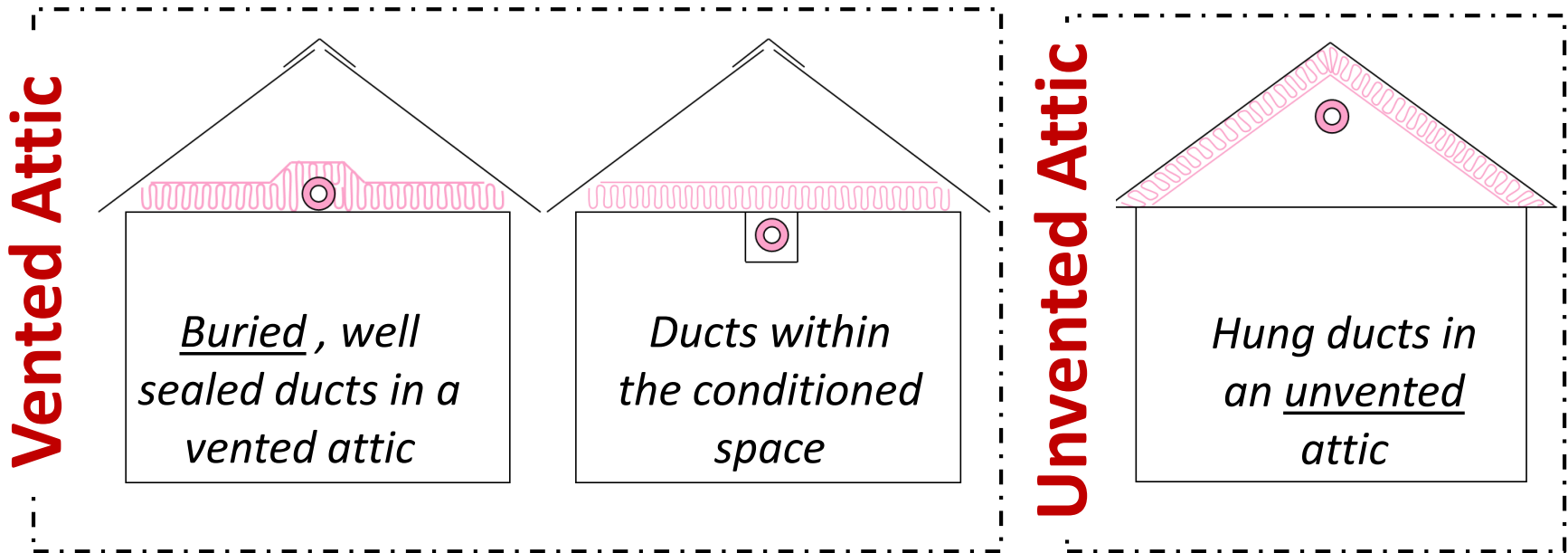

Image credit: U.S. Department of Energy
<https://energy.gov/eere/buildings/doe-zero-energy-ready-home-partner-central>

ZERO

High Performance Options

Goal: reduce energy consumption associated with HVAC systems in residential applications (thermal losses, duct leakage)



Buried ducts are now a recognized practice in the 2018 IECC

Let's talk about buried ducts!



TOPICS

■ What are buried ducts?

Concept

Code language

■ Do they work?

Field data

Cost/energy examples

■ How do you install them?

Ductwork

Attic insulation

Buried ducts: what are they?



High-Performance Ducts in a Vented Attic

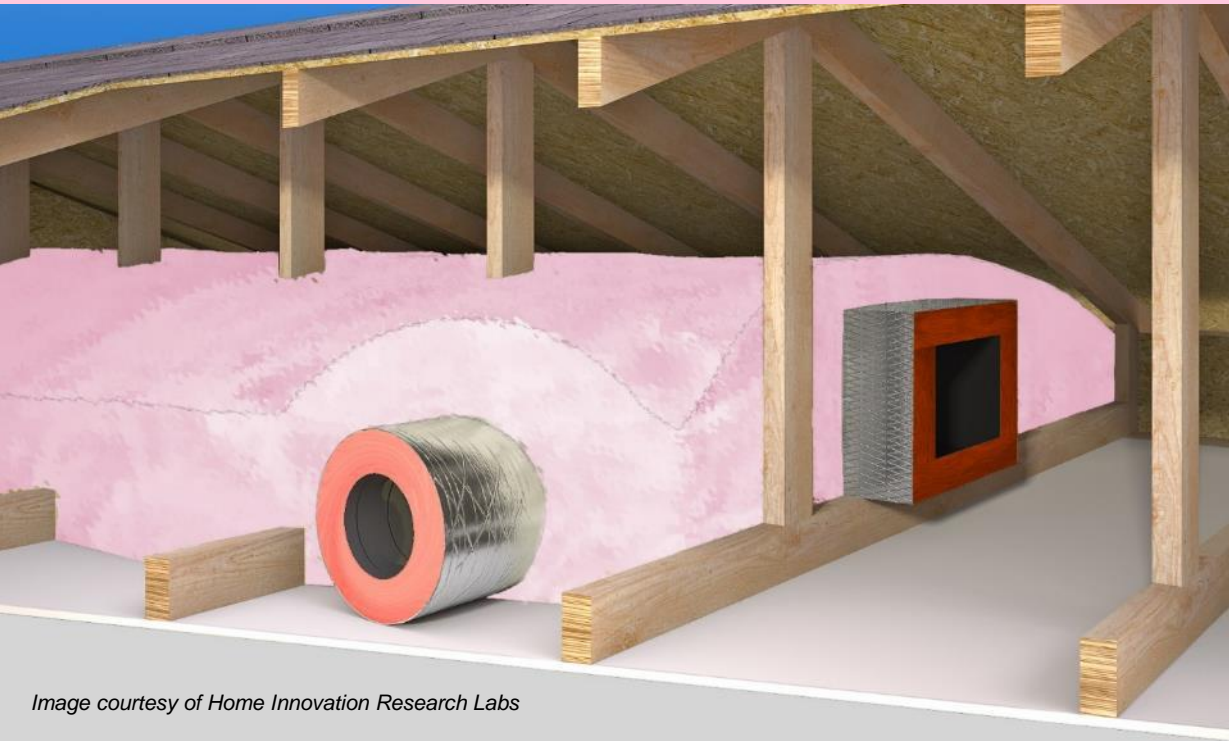

- Ducts placed on the ceiling drywall or over the bottom truss chords.
- Attic insulation covers (buries) the ducts.
- Reduces thermal losses from ducts located in vented attics.

Burying ductwork improves thermal performance and reduces energy usage.

Buried ducts have been approved in 2018 IECC



R-Value Requirements (for condensation)

1. Supply and return ducts insulated to minimum of R-8.
2. CZ's 1A, 2A, and 3A supply ducts under ceiling insulation, insulated to minimum of R-13.

Effective R-Value (for energy modeling)

1. Buried according to R403.3.6 (duct R-value, min. insulation above and below duct).
2. Installed directly on or within 5.5" of ceiling.
3. Surrounded by \geq R-30 attic insulation and top of the duct is buried a minimum of 3.5" below the attic insulation.

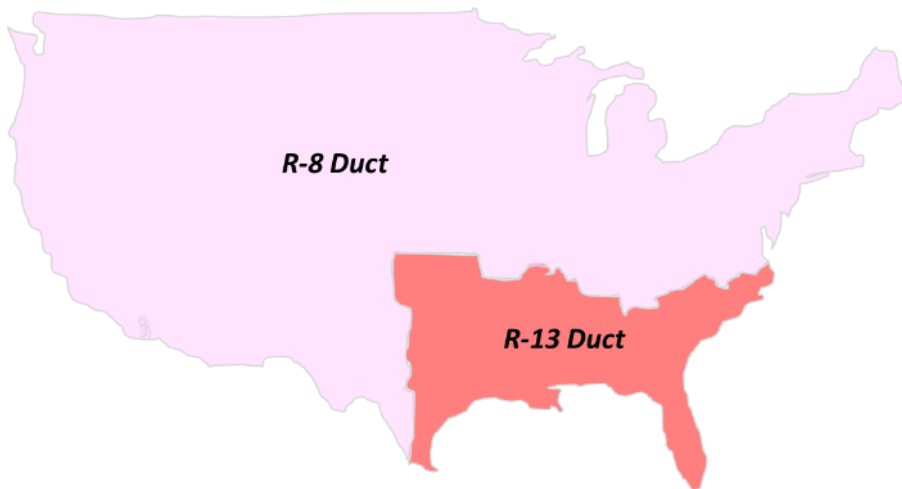

Color demarcations represent duct R-value requirements by region according to the International Energy Conservation Code climate zone map.

Deeply buried ducts may claim effective duct insulation of R-25

Buried ducts have been approved in 2018 IECC



'Conditioned Space' Criteria (for energy modeling)

1. Buried according to R403.3.6 (duct R-value, min. insulation above and below duct).
2. Total system leakage to outside is less than 1.5 CFM per 100sf CFA.
3. Insulation R-value against and above the duct \geq ceiling R-value – duct R-value.
4. Air handler located within the continuous air barrier and building thermal envelope.

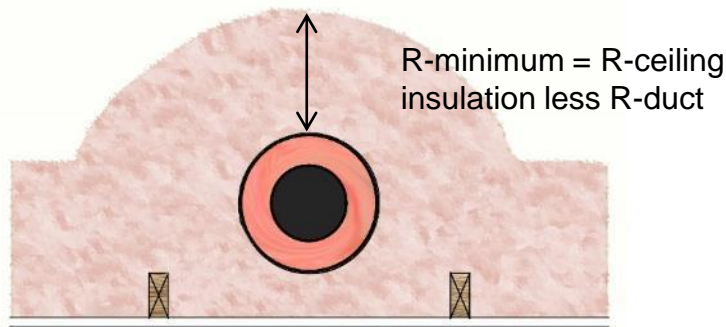

Image courtesy of Home Innovation Research Labs

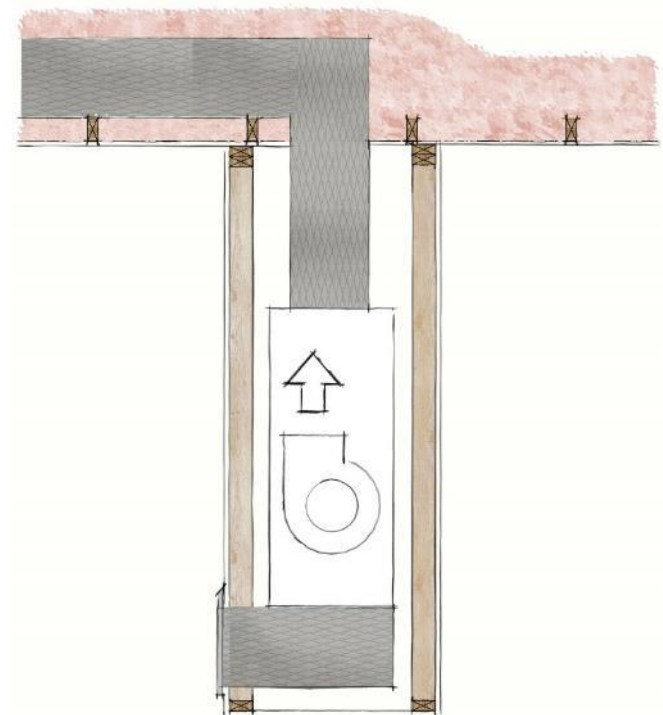

Image courtesy of Home Innovation Research Labs

Home Innovation Research Labs. TechSpecs A Builder's Blueprint for Construction Technologies (March 13, 2017). HVAC Ducts Buried Within Ceiling Insulation in a Vented Attic (Buried Ducts).

Source: 2018 International Energy Conservation Code®

Buried Ducts in California Title 24 Manuals



Buried Duct

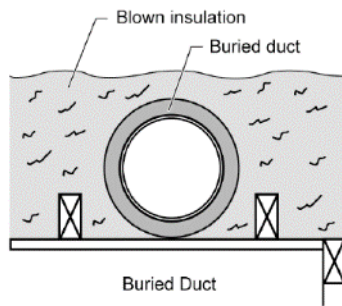

Source: California Energy Commission

- Ducts on drywall or within 3.5" of drywall
- Effective R-value based on duct size and attic insulation (Residential ACM Manual)

Deeply Buried Duct

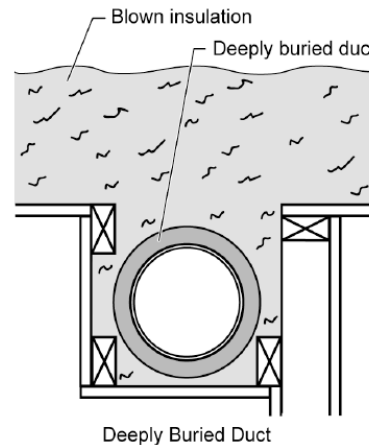

Source: California Energy Commission

- Enclosed in lowered portion of ceiling and completely covered by attic insulation
- Effective R-value = R-25 (fiberglass)

Deeply Buried Duct*

**Note: not approved practice. Language is being proposed to the CEC.*

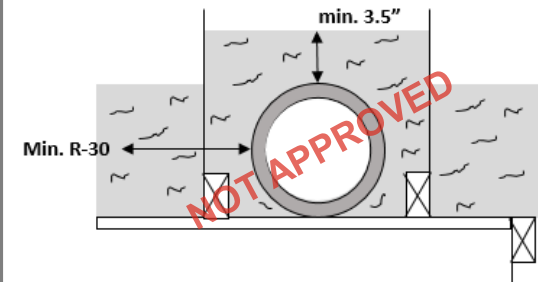

Drawn by K. Keeley, adapted from CEC buried duct image.

- *Proposed* vertical containment to maintain 3.5" insulation over the duct.
- Effective R-value = R-25 (fiberglass)

California Buried Duct Effective R-value Tables



Table 14: Buried Duct Effective R-values

	Nominal Round Duct Diameter								
Attic Insulation	4"	5"	6"	7"	8"	10"	12"	14"	16"
Effective Duct Insulation R-value for Blown Fiberglass Insulation									
R-30	R-13	R-13	R-13	R-9	R-9	R-4.2	R-4.2	R-4.2	R-4.2
R-38	R-25	R-25	R-25	R-13	R-13	R-9	R-9	R-4.2	R-4.2
R-40	R-25	R-25	R-25	R-25	R-13	R-13	R-9	R-9	R-4.2
R-43	R-25	R-25	R-25	R-25	R-25	R-13	R-9	R-9	R-4.2
R-49	R-25	R-25	R-25	R-25	R-25	R-25	R-13	R-13	R-9
R-60	R-25	R-25	R-25	R-25	R-25	R-25	R-25	R-25	R-13
Effective Duct Insulation R-value for Blown Cellulose Insulation									
R-30	R-9	R-4.2	R-4.2	R-4.2	R-4.2	R-4.2	R-4.2	R-4.2	R-4.2
R-38	R-15	R-15	R-9	R-9	R-4.2	R-4.2	R-4.2	R-4.2	R-4.2
R-40	R-15	R-15	R-15	R-9	R-9	R-4.2	R-4.2	R-4.2	R-4.2
R-43	R-15	R-15	R-15	R-15	R-9	R-4.2	R-4.2	R-4.2	R-4.2
R-49	R-31	R-31	R-15	R-15	R-15	R-9	R-9	R-4.2	R-4.2
R-60	R-31	R-31	R-31	R-31	R-31	R-15	R-15	R-9	R-9

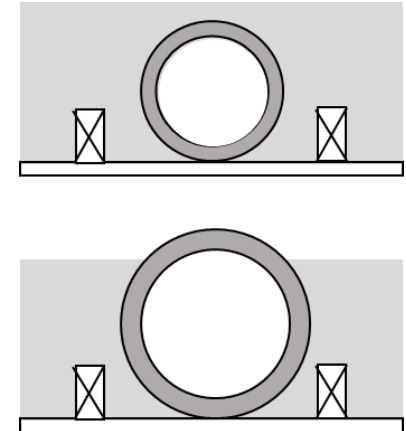

2016 California Residential ACM Reference Manual

- Effective R-value determined by the above table (mounding of attic insulation over ducts is not recognized).
- Increase effective R-value by increasing attic insulation depth (max. is R-25 for fiberglass).
- Proposed calculation of weighted duct R-value as inputs to software (supply and return duct).

California Buried Duct Requirements



Current requirements to take credit for buried or deeply buried ducts (based on 2016 California Residential Compliance Manual and Residential Appendices)

1. Verified Duct Design

- Field verified by rater to confirm ducts are installed according to the design, including location, size and length of the ducts, duct R-value, and installation of buried ducts.

2. Tested for Duct Sealing

3. Quality Insulation Installation (QII)

Other criteria for installation of buried ducts:

1. Min. duct R-value

2. Max. distance allowed from the drywall

3. Signage, markers

Proposed modifications include removing verified duct design as a requirement if duct leakage, fan watt draw, and air flow requirements are met.

The journey from concept to application

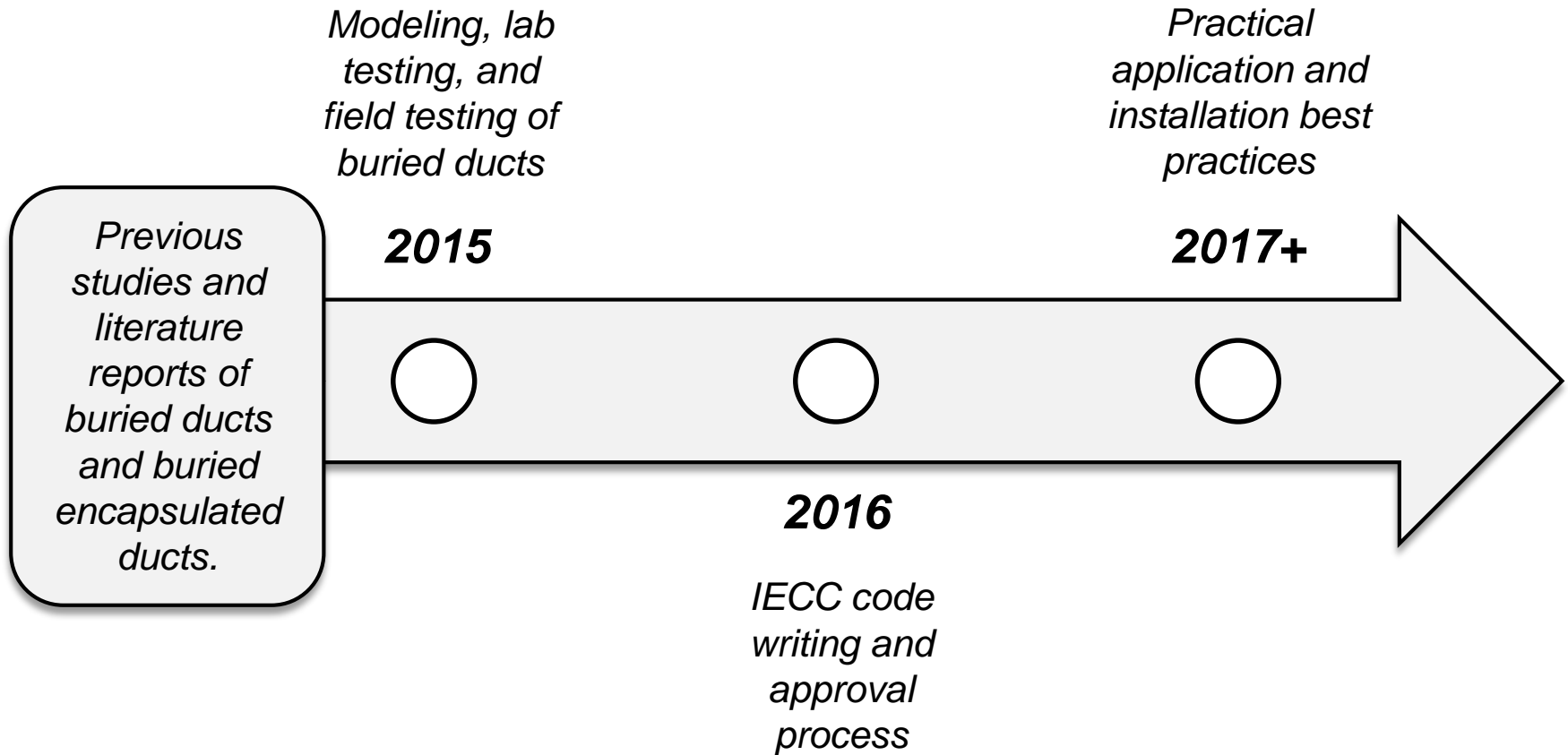

Climate Zone 5A

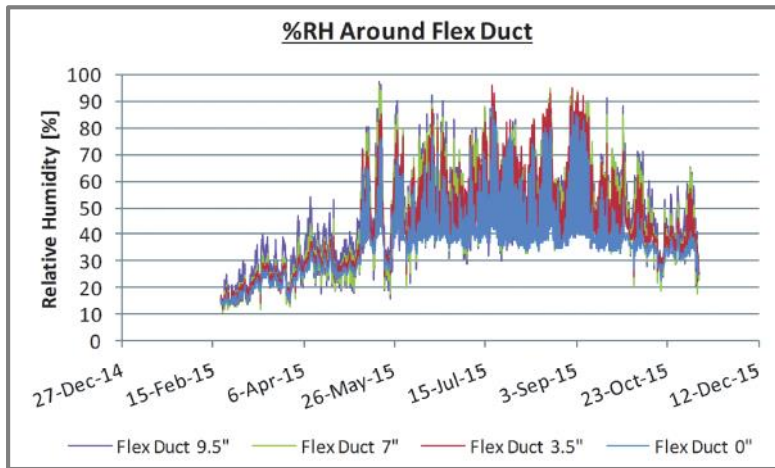

Copyright 2016 ASHRAE. Published in Thermal Performance of Exterior Envelopes of Whole Buildings XIII, Conference Papers.

- Data records every 30 minutes.
- Data point represents 30 minutes...hours in table are approximate.

- R-8 insulated ducts
- R-49 fiberglass loosefill
- Temp/humidity probes installed around flexible duct and throughout loosefill
- Data collection February '15 through March '16 (graph represents data through Nov '15).
- Limited days (May through Sept) of elevated humidity. High humidity followed by low humidity.

Table 1. Hours above Specified Humidity for Each of the Sensors Installed around an R-8 Buried Flexible Duct with 6812.5 Total Hours of Data Collection

	Hours $\geq 80\%$ rh	Hours $\geq 85\%$ rh	Hours $\geq 90\%$ rh	Hours $\geq 95\%$ rh
Flex 0 in. (bottom)	37	9.5	0	0
Flex 3.5 in. (middle)	176	74.5	22	2
Flex 7 in. (middle)	122.5	39.5	12	1
Flex 9.5 in. (top)	126.5	49.5	13.5	1.5

Copyright 2016 ASHRAE. Published in Thermal Performance of Exterior Envelopes of Whole Buildings XIII, Conference Papers.

No signs of condensation observed around the ducts or on the drywall.

In-Field Performance Data – Owens Corning



Climate Zone 4B

R-8 ducts, data collection beginning Oct '17

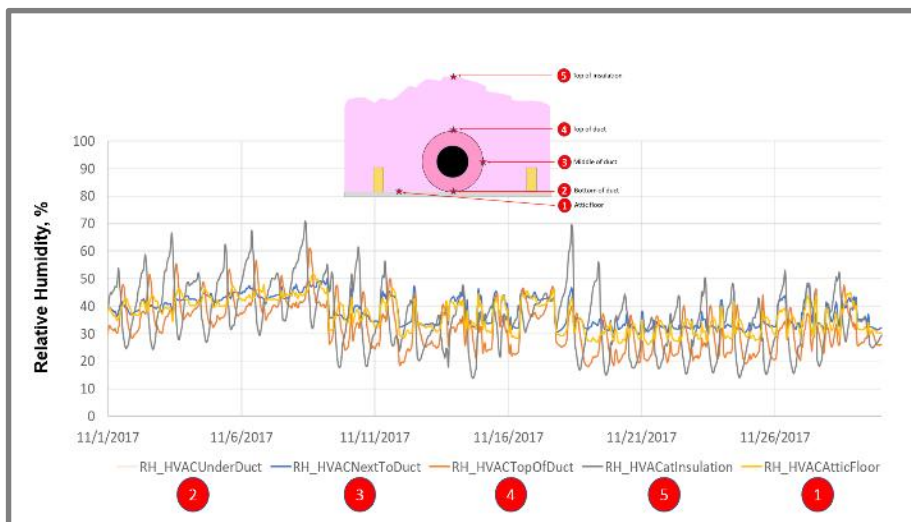

Climate Zone 2A

R-13 ducts, data collection beginning Nov '17

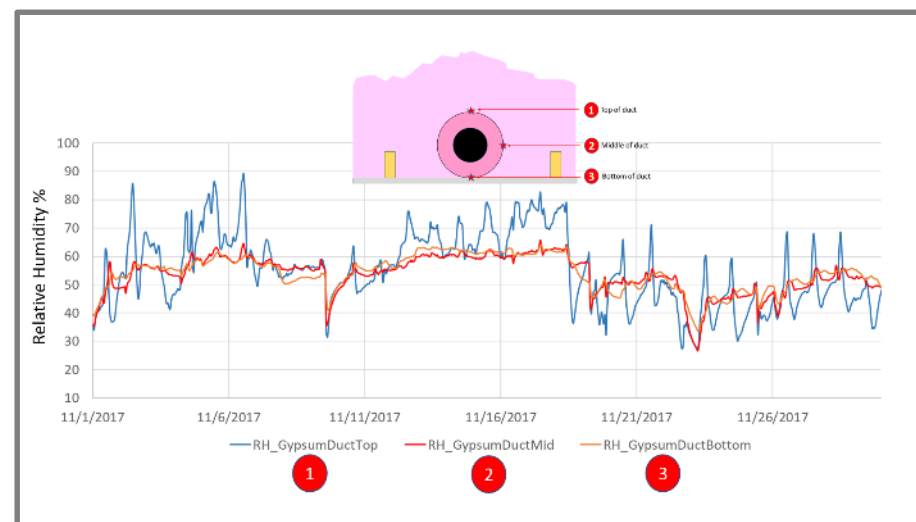

No condensation issues to-date, data collection continuing through 2018 to provide full year data capture

**Data collection on-going. Data presented represents November 2017 performance data.*

Building America Study – Compact Buried Ducts in Climate Zone 3A

- Buried Ducts versus Not Buried
- R-8 flex duct, R-8.7 duct board
- R-38 attic, R-30 mounded
- Graph (right): worst case duct conditions during worst case outdoor conditions.



After attic insulation was installed (shown), additional R-30 insulation was mounded above the ducts.

Image credit: Home Innovation Research Labs

https://energy.gov/sites/prod/files/2016/02/f29/ba_case_study_65261.pdf

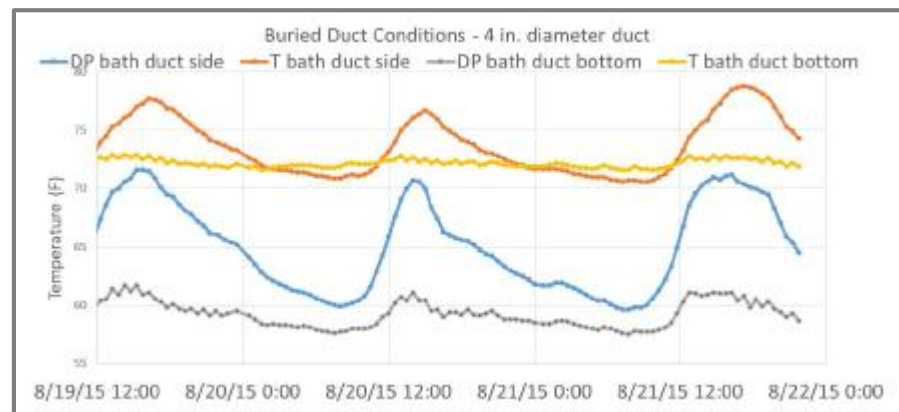

Image credit: Home Innovation Research Labs

https://www1.eere.energy.gov/buildings/publications/pdfs/building_america/compact-buried-ducts-hot-humid.pdf

- Dew point gradient within insulation
- No measured or observed condensation (Aug '15)
- Supply temperature from register 6.8°F cooler on average

*Data from :

D. Mallay, Home Innovation Research Labs, National Renewable Energy Laboratory & Building America Program, (January 2016). Compact Buried Ducts in a Hot-Humid Climate House.

Installed cost and energy savings example



Buried, Compact Duct

- Energy modeling via ACCA Manual J software
- Beaufort County, SC
- R-8 ducts, R-30 blown insulation over the ducts
- Compact layout
- Reduced duct leakage (estimated 1.1 cfm25/100ft² conditioned floor area for energy analysis)

Image credit: Home Innovation Research Labs https://energy.gov/sites/prod/files/2016/02/f29/ba_case_study_65261.pdf

- **Estimated annual heating and cooling savings (all ducts buried) = \$281 versus baseline (21.2% energy savings)**
- **HIRL estimated incremental cost = \$732**
 - +\$720 material and labor (mechanical closet)
 - -\$400 elimination of pull-down stairs, AHU platform, condensate pan
 - +\$412 blown insulation
 - Reductions for compact duct not included (↓ 32% supply, ↓ 75% return)
- **Simple payback = 3.1 years, return on investment = 32.2%**

*All data/estimates from :

D. Mallay, Home Innovation Research Labs, National Renewable Energy Laboratory & Building America Program, (January 2016). Compact Buried Ducts in a Hot-Humid Climate House.

Installed Cost Analysis (Building America Report)



Table 5. Example Cost for 2,400-ft² Single-Story House With 6:12 Gable Roof in Climate Zones 1, 2, or 3. Duct Surface Areas Based on BA Benchmark With Two Returns

	Partially Buried	Fully Buried	Deeply Buried	Unvented ccSPF	Encapsulated	Partially Buried and Encapsulated	Fully Buried and Encapsulated	Deeply Buried and Encapsulated	Interior Ducts
R-30 ccSPF Roof Deck ^a				\$8,363					
Encapsulated ducts ^{a,b}					\$1,678	\$1,678	\$1,678	\$1,678	
Partially Buried (R-33 Fiberglass) ^c	\$95								
Fully Buried (R-42 Fiberglass) ^c		\$380							
Deeply Buried (R-51 Fiberglass) ^c			\$665						
Partially Buried and Encapsulated (R-37 Fiberglass) ^c						\$222			
Fully Buried and Encapsulated (R-46 Fiberglass) ^c							\$507		
Deeply Buried and Encapsulated (R-54 Fiberglass) ^c								\$760	
Interior Ducts ^d									\$1,680
Total Cost	\$95	\$380	\$665	\$8,363	\$1,678	\$1,900	\$2,185	\$2,439	\$1,680

^a Costs from RSMMeans Residential Cost Data (RSMMeans 2011).

^b BA Benchmark assumes 888 ft² of ductwork. Actual ductwork surface area ranged from 218 ft² to 681 ft² for the three homes monitored by Shapiro et al. (2012). Costs for installations may be significantly lower than the cost cited here.

^c Costs from the National Residential Efficiency Measures Database (NREL 2012).

^d Cost from Beal et al. (2011).

C. Shapiro, W. Zoeller, and P. Mantha, CARB, National Renewable Energy Laboratory & Building America Program, (August 2013). Measure Guideline: Buried and/or Encapsulated Ducts. Page 19. <https://www1.eere.energy.gov/buildings/publications/pdfs/building_america/measure_guide_buried_encap_ducts.pdf>

Buried ducts (non-encapsulated) are lowest installed cost

Energy Rating Index Score Example



Example ERI Comparison

for illustrative purposes only, completed using REM/Rate v15.4.1

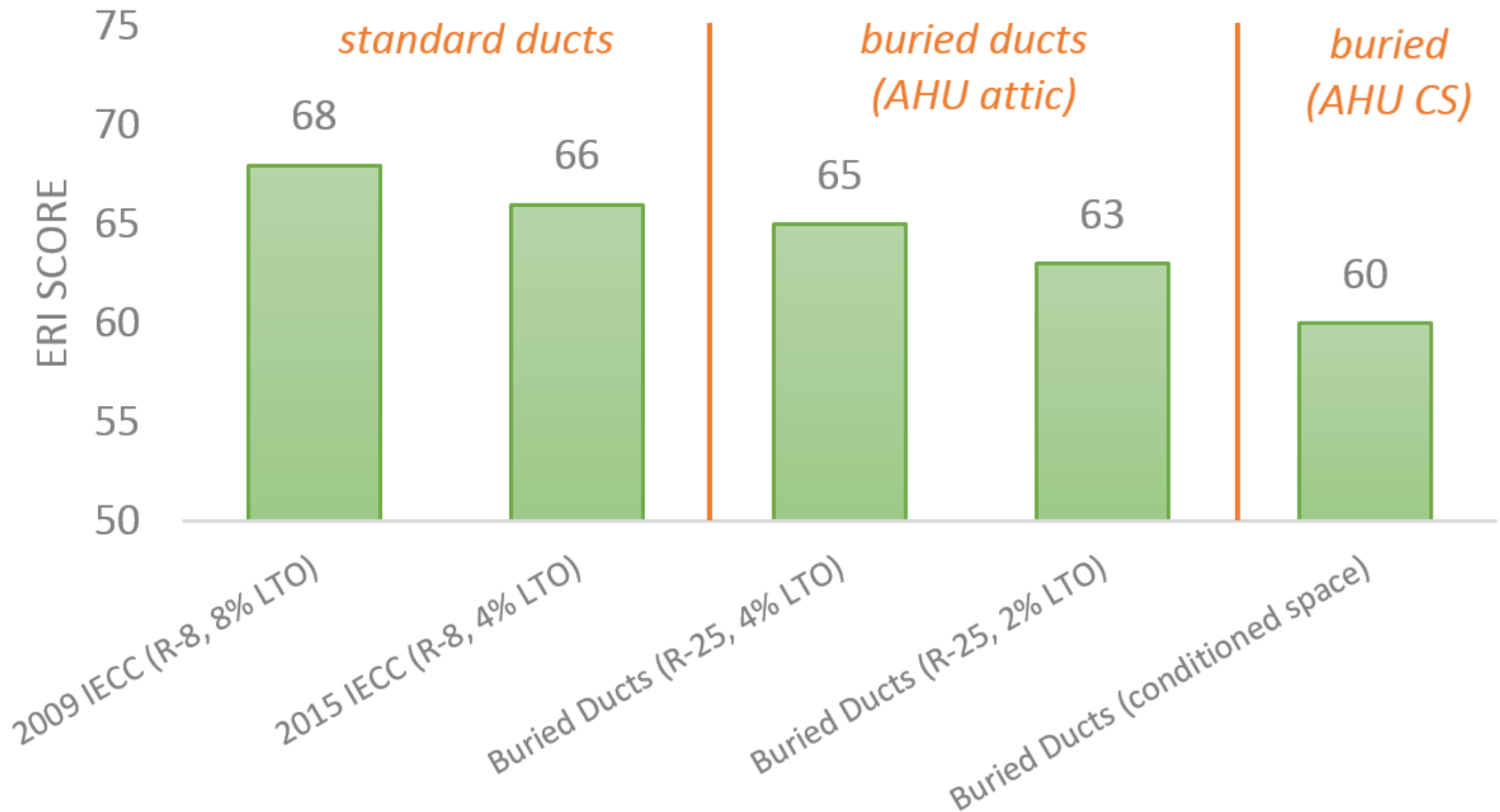

**Compliance analysis should be completed by a qualified energy rater.

**Energy modeling software packages may update to reflect this new code language.

Installing Buried Ducts

Buried Duct Installation Guidelines



Buried Duct Installation Guidelines

Before you start you need to know the following:

1. Ceiling insulation R-value
2. Which option of buried duct you are going to use
3. All standard duct design data

HVAC Duct System

1. Planning

- a. Recommend using a "compact duct design" for better airflow, less energy loss, lower cost and faster install.
- b. Develop duct layout with the trunk duct normally running perpendicular to the trusses while sitting on the bottom truss cord.
- c. Register runouts should have side take-offs along the trunk and be hung between the trusses when possible, so they will lay on the ceiling drywall. Do not allow the ducts to hang below the bottom of the trusses.
- d. Supply and return register boots should be the side tap style to keep the flex duct low.
- e. Supply and return register boots should be sealed and insulated to the correct R-value.
- f. Avoid as much as possible ducts from crossing over each other.
- g. Check to be sure there is enough space above the ducts to blow the correct thickness of insulation based on which option you are working from.
- h. Look for opportunities to group ducts together without touching so that there will be less individual mounding of insulation.
- i. If the unit is in the attic, do not use top take-off from the plenum.
- j. Clearly mark HVAC ducts to be buried with flags that indicate the correct thickness of insulation to be on top of the duct.
- k. Check for enough space to dam insulation around vertical ducts.

2. Installation

- a. Install ductwork per plan making sure all joints, connectors, supply and return boots and all duct punctures are sealed against air leakage.
- b. Seal all boots thru the drywall connections
- c. Insulate all ducts and supply and return boots to the correct R-value. R-8 is required except in zones 1A, 2A, & 3A which requires R-13 on the supply ducts and boots.

Attic Insulation

1. Planning

- a. If Studor vents are being used in the attic, check to be sure they will not be buried in the insulation. If so, plan on moving them so they will not be buried.
- b. Determine the length of Raft-R-Mate® attic vent required so not to blow insulation into the openings.
- c. Determine the design and amount of insulation dam materials need around the access openings, AC/furnace unit and plenum, vertical ducts, and cathedral ceilings. ProPink® Fanfold (1/4" thick foam), 1/2" foam sheathing, or wood framing and fabric are some options.

2. Installation

- a. Add lengths of Raft-R-Mate® attic vent as needed.
- b. Install insulation dams around the access openings, AC/furnace unit and plenum, vertical ducts, and cathedral ceilings.
- c. Air seal around all ceiling penetrations including can lights.
- d. Add insulation depth gauges to top of duct runs to assure the correct amount of insulation to cover the ducts.
- e. Blow the attic so that the correct insulation depth is achieved and all the ducts are buried to the correct depth.

Things to Know

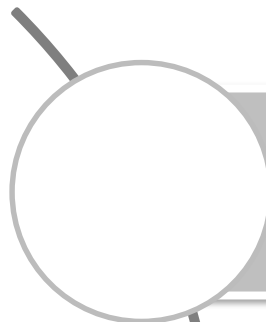

Ceiling insulation R-value

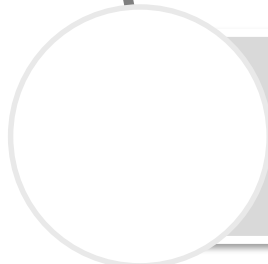

Standard duct design data

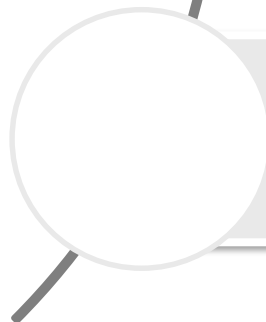

Buried duct approach (R-25 credit or conditioned space criteria)

Aspects of installing buried ducts

Utilizes same trades as standard practice of ducts in a vented attic

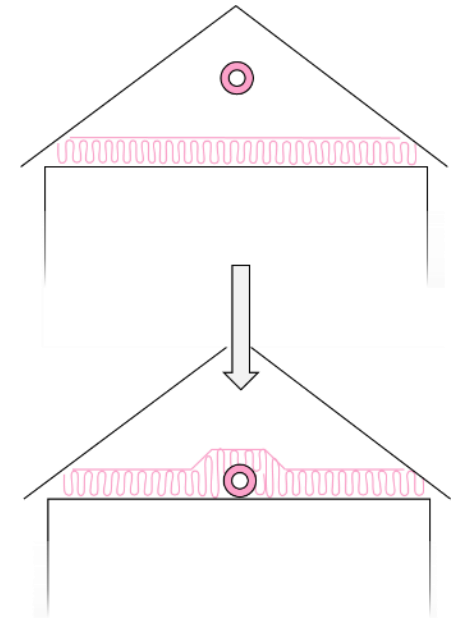
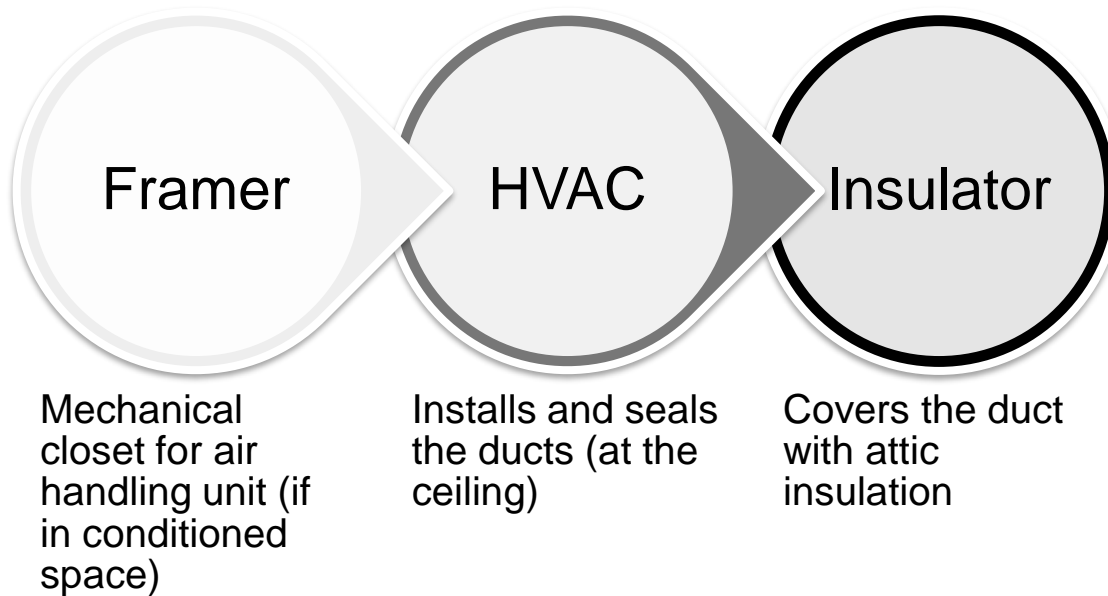

Consider using a “compact duct design”

- Opportunity for improved airflow and increased energy performance
- Lower cost
- Faster installation and easier burying

Configure ducts in 2D plane rather than 3D space

- Trunk and branch layout may be optimal
- Trunk duct on bottom chord; run outs between trusses on ceiling drywall
- Do not allow ducts to hang below truss chords.

Duct system should be well sealed

- Reducing duct leakage alone improves performance
- Tight duct requirement for conditioned space criteria

Proper duct R-value

- Minimum R-8 ducts
- R-13 supply ducts in climate zones 1A, 2A, and 3A

Compact Design and Proper Installation

Consider “compact duct design” for improved performance and installation; ensure proper installation of flexible ducts

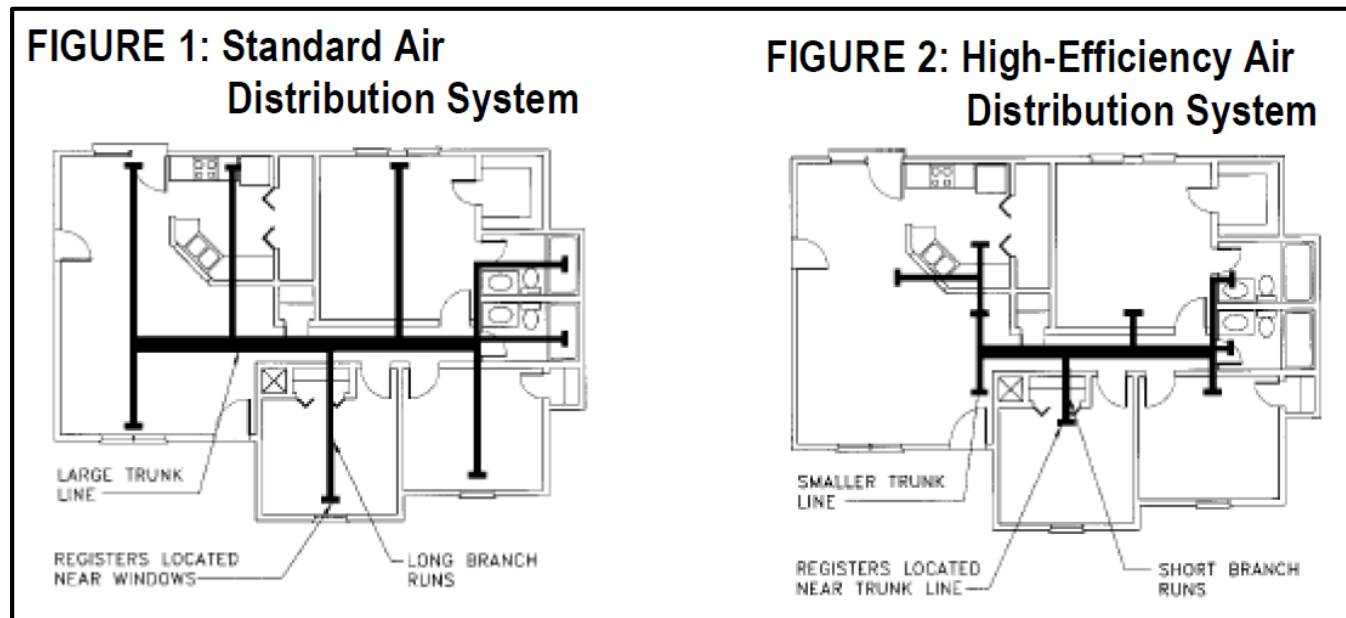

Image credit: U.S. Environmental Protection Agency, ENERGY STAR Program

https://www.energystar.gov/ia/home_improvement/home_sealing/RightSized_CompactDuctsFS_2005.pdf?8fd5-1967

Keep ducts flat to the attic floor

Use side mount taps on plenum/trunk and boot connections



Image credit: Home Innovation Research Labs

https://energy.gov/sites/prod/files/2016/02/f29/ba_case_study_65261.pdf

Keep ducts flat to the attic floor

Use side mount taps supply boot connections



Keep ducts flat to the attic floor

Use side mount taps on return boot connections



Keep ducts flat to the attic floor

Avoid having ducts cross over one another; try to mitigate at design phase



Boots should be sealed and insulated

Insulate to the same R-value as the connecting duct



Duct R-Value based on region

R-13 required for supply ducts in CZ 1A-3A. Home Innovation Research Labs TechSpec shows how to get to R-13 ducts using common duct insulation today.

Table 1. Common duct insulation types and example methods to achieve R-13 duct insulation.

Duct Construction/Insulation (commonly available R-values)	Example Methods to Achieve R-13 Duct Insulation ^a
<p>Flex Duct: prefabricated, round, flexible duct with a wire helix for support, commonly available with fiberglass insulation between the inner “liner” and outer “jacket” vapor barriers. (R4.2, R6, R8)</p>	<ul style="list-style-type: none"> • Concentric flex ducts: R-8 within R-6 • R-5 (installed R-value) duct wrap over R-8 flex ducts • R-13 (installed R-value) duct wrap over uninsulated flex duct • R-13 flex duct when it becomes available
<p>Duct Board: shop fabricated using foil-faced rigid fiberglass sheets. (R-4.2, R-6, R-8.7)</p>	<ul style="list-style-type: none"> • R-13 duct board is available but not common • R-6 duct board over R-8 duct board • R-5 (installed R-value) duct wrap over R-8 duct board
<p>Duct Wrap: flexible rolls of foil-faced fiberglass insulation installed over metal ducts and fittings in the shop or field. Use the “installed” R-value on the label or the manufacturer’s specification.</p>	<ul style="list-style-type: none"> • R-13 (installed R-value) is available but not common • R-5 (installed R-value) duct wrap over R8 (installed R-value) duct wrap

^a Layering duct insulation over duct insulation can create a double vapor barrier configuration. This is not considered a concern provided the outer layer is properly sealed to protect against moisture drive from the attic. The inner layer acts a back-up layer of protection.

Courtesy of Home Innovation Research Labs

Account for space above the ducts

Ducts should be installed so that there is enough space above the duct to account for the proper thickness of insulation



Duct sealing requirement and improved performance

Requirement to achieve 'conditioned space criteria' is 1.5cfm/100ft² of conditioned floor area at rough-in or post construction leakage to the outside
(AHU located within conditioned space – would not contribute to leakage to outside)

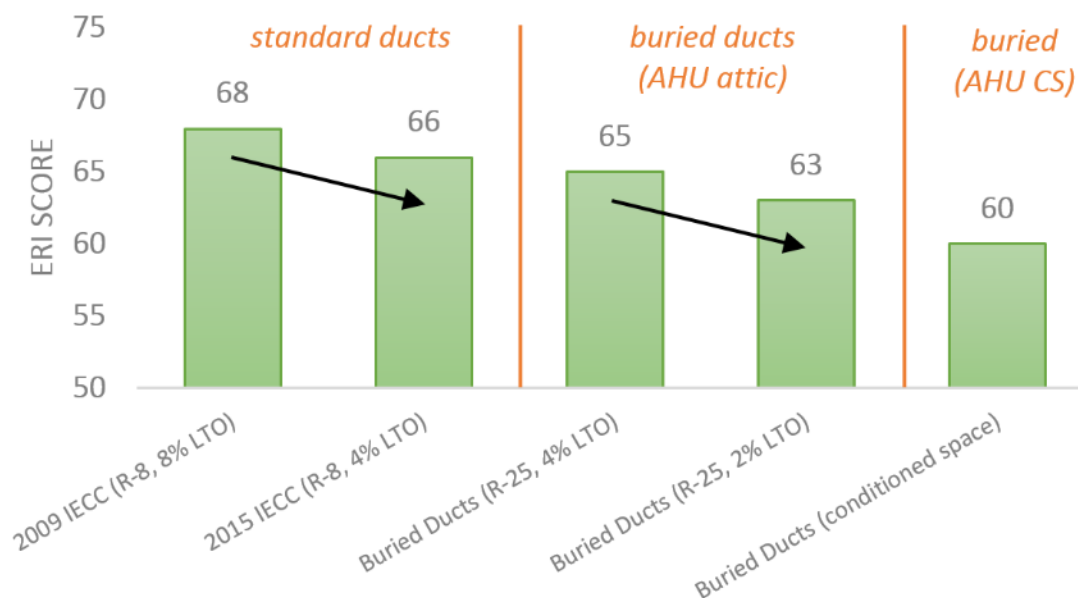

Reducing duct leakage alone improves performance

Duct sealing boot-drywall connection

Boot-drywall connection should be sealed



Summary

1. Keep the ducts flat to the attic floor
2. Use side mount taps everywhere
3. Minimize ducts from crossing over each another
4. Seal all connections and seal and insulate all boots

Installing Attic Insulation

Install insulation depth gauges

To show duct location and assure correct depth of insulation burying the ducts.



Air baffles may be needed for ducts close to the eaves

To prevent insulation from entering the baffle and stopping air flow



Insulation dams may be needed

Area around unit and vertical ducts may require insulation dams

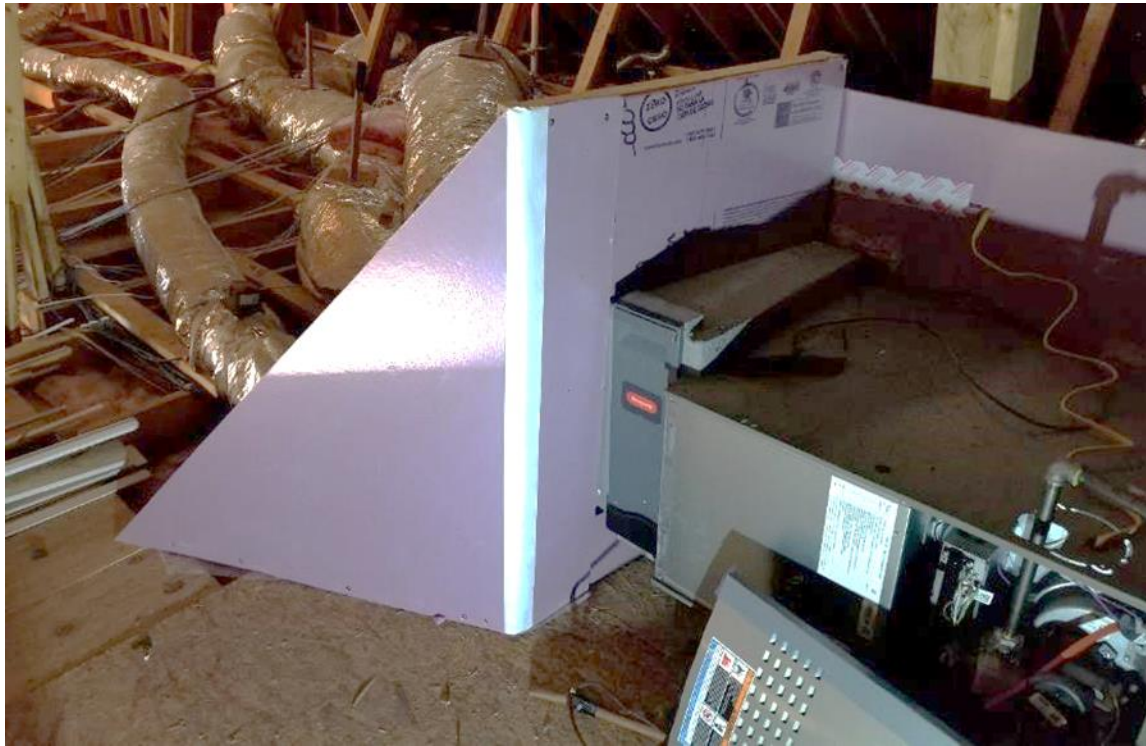

Attic Insulation Design Points

Burying the ducts to the correct insulation depth



Attic Insulation Design Points

Burying the ducts to the correct insulation depth



Summary

1. Insulation depth gauges installed at regular intervals
2. Extra air baffles may be needed
3. Insulation dams around unit and vertical ducts

If you have been thinking about...

- Reducing ERI scores or improving code compliance
- Installing unvented attics or ducts in the conditioned space
- Using other energy efficiency measures or trade offs

Tight and buried ducts provide a viable building practice to achieve code compliance and energy credit with the 2018 code.

AND...

- are easier to implement than other approaches
- are a low or no incremental cost option

